



BF2/BF3

Internally threaded 2- and 3-way control valves

Valves designed for control of hot, cold or glycol-mixed water in heating and ventilation systems. The valves are intended for use together with Regin's RVAN5.../RVAN10... actuators.

- ✓ Size DN15...DN50
- ✓ Kvs value 0.63...40
- ✓ Media temperature -5...+140°C
- ✓ Pressure rating PN16
- ✓ Rangeability 100:1

Function

2-way valve

The valve is open when the stem is in its lowest position and closed when the stem is in its top position.

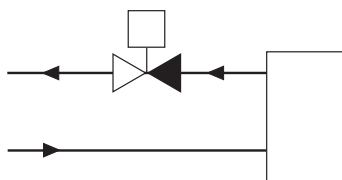

2-way valve

The 3-way valve is closed between port A and port AB (the ports opposite to one another) when the stem is in its highest position. In this position, the valve is also open between the bottom port B and the common supply port AB. When the stem is in its lowest position, the 3-way valve is completely open between port A and port AB and consequently closed between the bottom port B and the common port AB.

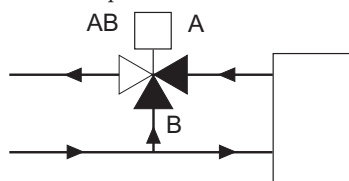

3-way valve

Installation

The 2-way valve should be mounted with port A on the inlet and port AB on the return (flow direction A in, AB

out) to ensure that the plug closes tightly and to prevent any noise when closing.

The 3-way valve is of a mixing type and must therefore be mounted in the mixing point.

- Before installation of the control valve, ensure that the pipe is clean. Make sure that pipe scale, metal chips, welding slag and other foreign materials are removed.
- For maximum efficiency and minimum wear, install the valve in a vertical position with the stem pointing upward. If the valve is mounted with the actuator on the side, more wear is caused to the valve stuffing box. The valve should never be mounted at an angle of more than 90°.

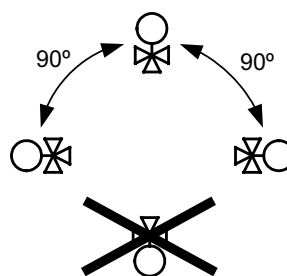

- Install the valve according to the fluid direction arrow shown on the valve.
- Make sure there is ample space above the valve to facilitate easy removal of the valve actuator.

Fit a strainer/filter upstream of the valve to prolong the equipment's life span.

A water quality according to VDI 2035 is recommended.

Technical data

Application	Heating systems, cooling systems, ventilation systems
Pressure rating	PN16
Connection	BSP internally threaded according to ISO 228/1
Flow characteristics	A - AB = equal percentage, B - AB = linear
Max. leakage	0.1 % of Kvs
Media	Hot water, cold water, glycol-mixed water (max. 50 % glycol)
Media temperature	-5...+140 °C
Rangeability	100:1
Stroke	20 mm

Material

Body	Brass CW614N
Seat	Brass CW614N
Plug	Brass CW614N
Stem	Stainless steel 1.4305
Packing box	Brass CW614N
O-rings	EPDM

2-way valves

Article	Nominal diameter	Kvs
BF215-0.63	DN15	0.63
BF215-1.0	DN15	1.0
BF215-1.6	DN15	1.6
BF215-2.1	DN15	2.1
BF215-2.7	DN15	2.7
BF220-4.2	DN20	4.2
BF220-5.6	DN20	5.6
BF225-10	DN25	10
BF232-16	DN32	16
BF240-25	DN40	25
BF250-40	DN50	40

3-way valves

Article	Nominal diameter	Kvs
BF315-0.63	DN15	0.63
BF315-1.0	DN15	1.0
BF315-1.6	DN15	1.6
BF315-2.1	DN15	2.1
BF315-2.7	DN15	2.7
BF320-4.2	DN20	4.2
BF320-5.6	DN20	5.6
BF325-10	DN25	10
BF332-16	DN32	16
BF340-25	DN40	25
BF350-40	DN50	40

Combination options (valves and actuators) and differential pressure

Type	ΔP_s (RVAN5...)	ΔP_{max} (RVAN5...)	ΔP_s (RVAN10...)	ΔP_{max} (RVAN10...)
BF215-0.63	1600 kPa	700 kPa	1600 kPa	700 kPa
BF215-1.0	1600 kPa	700 kPa	1600 kPa	700 kPa
BF215-1.6	1600 kPa	700 kPa	1600 kPa	700 kPa
BF215-2.1	1600 kPa	700 kPa	1600 kPa	700 kPa
BF215-2.7	1600 kPa	700 kPa	1600 kPa	700 kPa
BF220-4.2	1000 kPa	600 kPa	1600 kPa	600 kPa
BF220-5.6	1000 kPa	600 kPa	1600 kPa	600 kPa
BF225-10	600 kPa	500 kPa	1400 kPa	500 kPa
BF232-16	400 kPa	400 kPa	800 kPa	450 kPa
BF240-25	300 kPa	300 kPa	600 kPa	400 kPa
BF250-40	200 kPa	200 kPa	400 kPa	300 kPa
BF315-0.63	1600 kPa	700 kPa	1600 kPa	700 kPa
BF315-1.0	1600 kPa	700 kPa	1600 kPa	700 kPa
BF315-1.6	1600 kPa	700 kPa	1600 kPa	700 kPa
BF315-2.1	1600 kPa	700 kPa	1600 kPa	700 kPa
BF315-2.7	1600 kPa	700 kPa	1600 kPa	700 kPa
BF320-4.2	1000 kPa	600 kPa	1600 kPa	600 kPa
BF320-5.6	1000 kPa	600 kPa	1600 kPa	600 kPa
BF325-10	600 kPa	500 kPa	1400 kPa	500 kPa
BF332-16	400 kPa	400 kPa	800 kPa	450 kPa
BF340-25	300 kPa	300 kPa	600 kPa	400 kPa
BF350-40	200 kPa	200 kPa	400 kPa	300 kPa

ΔP_s constitutes the max. permitted differential pressure at which the valve actuator can safely close against the pressure.

ΔP_{max} constitutes the max. permitted differential pressure over the flow path of the valve for the entire actuating range of the actuator (i.e. open valve).

Dimensions

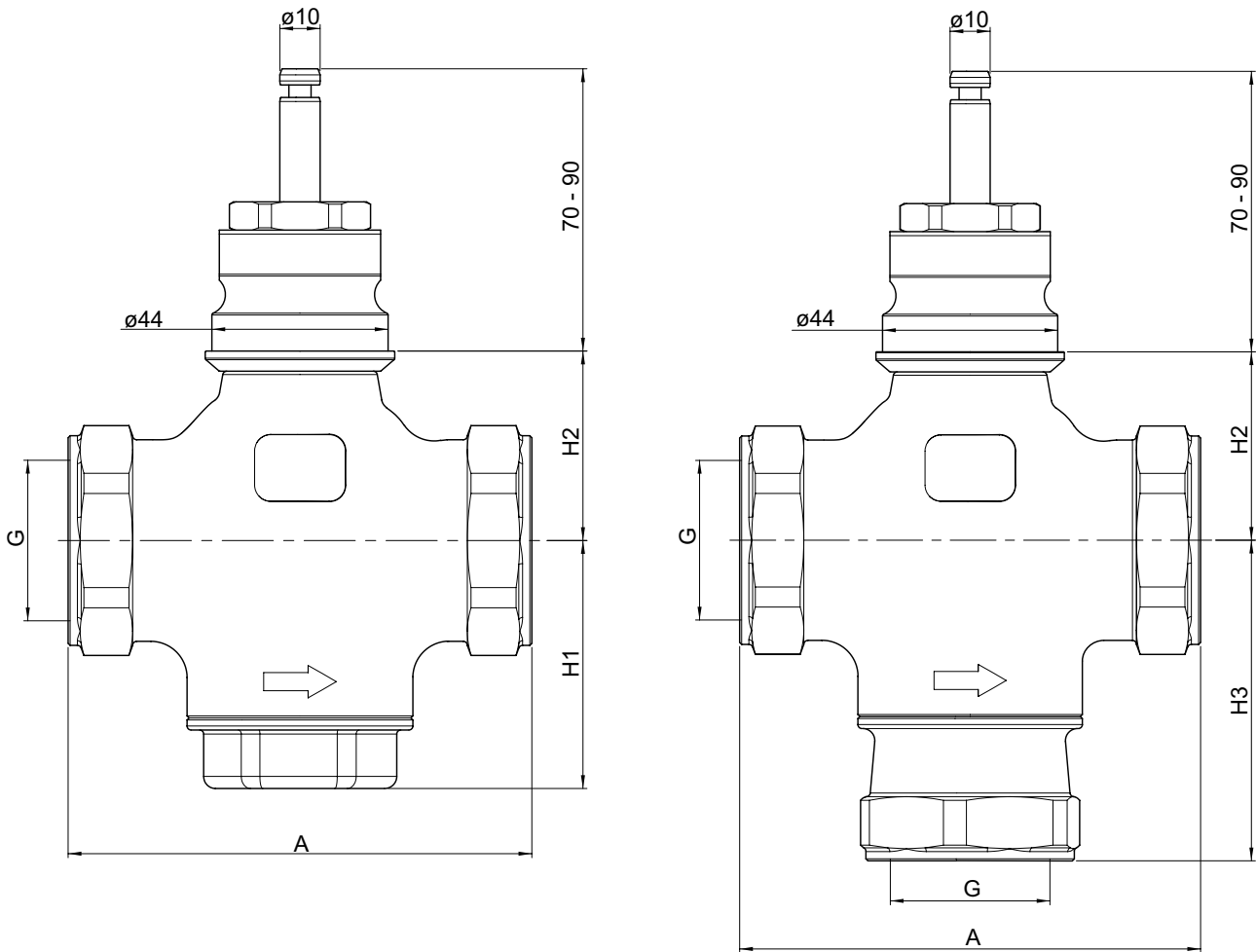

Nominal diameter	A	H1	H2	H3	G	Stroke
DN15	70	55	39	70	G 1/2"	20
DN20	80	55	39	70	G 3/4"	20
DN25	90	55	45	70	G 1"	20
DN32	115	62	47	80	G 1 1/4"	20
DN40	130	65	55	80	G 1 1/2"	20
DN50	160	67	61	95	G 2"	20

Measurements in mm unless otherwise specified.

Pressure drop curves

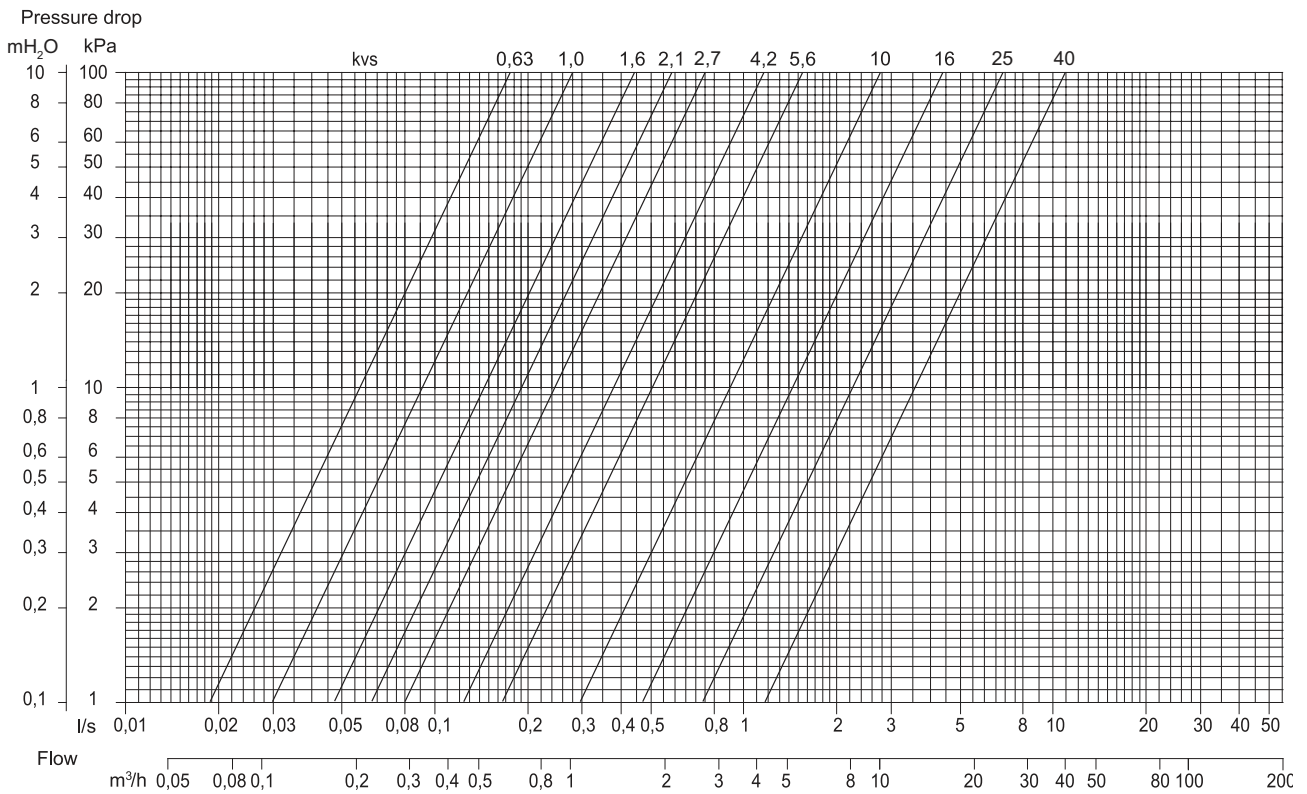

Example, pressure drop curves

If the pressure drop is 7 kPa (A) and the flow is 4 m³/h (B), a valve with the kvs value 16 (C) is preferably selected. See the markings in the picture to the right.

