



COF

Carbon monoxide transmitter

COF is intended for demand-controlled ventilation in e.g. parking garages and road tunnels.

- Electrochemical transmitter providing high selectivity
- Robust design with protection class IP56
- Linear output signal 4...20 mA or 0...10 V

COF is a detector intended for demand-controlled ventilation in parking garages and road tunnels etc. The detector is installed for both safety and energy-saving reasons. It measures the carbon monoxide concentration using an electrochemical method of measurement characterised by high selectivity even in low concentrations. The output signals are linear representations of the gas concentration.

About vehicle emissions

Carbon monoxide (CO) is produced by running petrol vehicles. All motor vehicles, except for natural gas vehicles, produce CO when cold-started. The gas is dangerous to inhale.

Limit values

The limit values for carbon monoxide may vary from one country to another. Please check local standards and regulations. The following limit values have been set up by the Swedish Work Environment Authority (according to AFS 2005:17, Occupational exposure limit values):

Level limit value (LLV)	35 ppm
Short-term value (STV)	100 ppm

However, when the gas comes from exhaust fumes, the level limit value is 20 ppm.

- Two-wire (4...20 mA) or three-wire (0...10 V) connection for easy installation
- TÜV-approved in accordance with VDI 2053
- Automatic zero adjustment facilitates maintenance

Control and alarm levels

We recommend using two alarm levels, pre-alarm and full alarm. In case of a pre-alarm, the fans are to be set to full speed and strategically placed flashing lights are to be activated. In case of a full alarm, strategically placed sirens are to be started, advising people to leave the garage immediately.

Recommended levels for these alarms:

Pre-alarm	50 ppm
Full alarm	100 ppm

Installation

COF is recommended to be mounted in breathing height, about 180 cm above the floor. One detector is to be placed per 200-500 square metres garage surface, provided that the surface is open (without any "pockets") and that there is continuous air flow. If there are any "service pits", a COF should be installed in each pit. The transmitter must be mounted with the cable connection pointing up.

Technical data

Supply voltage	12...28 V DC
Power consumption	20 mA
Method of measurement	Electrochemical
Outputs	4...20 mA, two-wire 0...10 V DC, three-wire
Calibration	Automatic zero adjustment
Ambient temperature	-10...+40°C
Ambient humidity	0...90 % RH
Protection class	IP56
Dimensions (WxHxD)	80 x 82 x 86 mm
Weight	0.190 kg
Material, casing	Polycarbonate
Type of gas	Carbon monoxide (CO)
Measuring range	0...300 ppm
Accuracy	±3 %
Lifetime sensor	~ 6 years



This product carries the CE mark. For more information, see www.regincontrols.com

This product is TÜV-approved in accordance with VDI 2053.

Wiring

The output signal is set via a jumper according to the figures below.

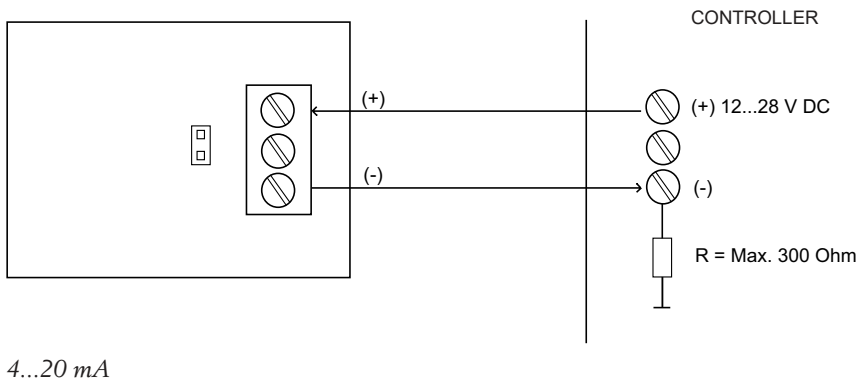
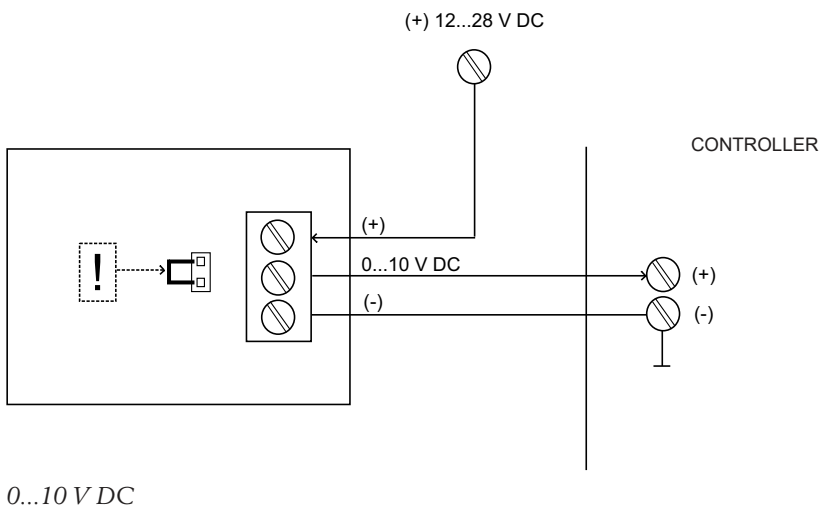

Head Office Sweden

Phone: +46 31 720 02 00

Web: www.regincontrols.com

Mail: info@regin.se