



CTV

Externally threaded 2-way zone valve

The valve range is intended to be used together with the RTA(O)M100 thermal actuators for temperature control in heating and cooling systems, such as radiators, convectors, chilled ceilings etc.

- ✓ Size DN10...DN20
- ✓ Kvs value adjustable between 0.12...1.9
- ✓ Media temperature 2...90°C
- ✓ Pressure rating PN10
- ✓ Compact design

Function

The valve is normally open. When using a NC actuator the valve is closed when no voltage is applied. Using a NO actuator will give the opposite result.

The valve is closed when the stem is in its lowest position and completely open in the highest position.

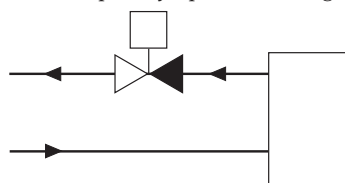

2-way valve

Setting of kvs value

The valve has a reference marking in the upper valve body. The kvs value is set using the grey plastic cap supplied with the valve.

Installation

The valves are supplied with a grey plastic cap which can be used to open/close the valve manually during system installation. Turning the plastic cap clockwise to its end position closes the valve.

- Before installation of the control valve, ensure that the pipe is clean. Make sure that pipe scale, metal chips, welding slag and other foreign materials are removed.
- The valve should never be mounted at an angle of more than 90°.

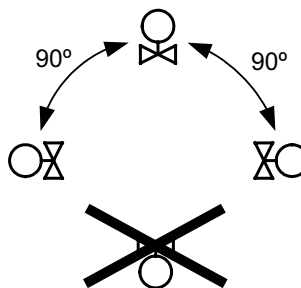

- Install the valve according to the fluid direction arrow shown on the valve.
- The actuator is mounted on the valve with the adapter (VA54) which is sold separately.

Technical data

Application	Heating systems, cooling systems, radiators
Pressure rating	PN10
Connection	BSP externally threaded according to ISO 228/1
Connection, actuator	M28 x 1.5
Flow characteristics	Linear
Max. leakage	0.0 % of the kvs value
Max. diff. pressure	150 kPa
Media	Hot water, cold water, glycol-mixed water (max. 30 % glycol)
Media temperature	2...90 °C
Stroke	3.5 mm

Material

Body	Chromed brass CW614N
Seat	Brass CW614N
Stem	Stainless steel 1.4305
O-rings	EPDM
Bonnet	Brass CW614N
Seat packing	NBR

Models

Article	Nominal diameter	Connection, external thread	Kvs (adjustable)	Actuator	Adapter
CTV10	DN10	G1/2"	0.12...1.14	RTA(O)M100	VA54
CTV15-1,9	DN15	G3/4"	0.17...1.9	RTA(O)M100	
CTV20	DN20	G1"	0.15...1.55	RTA(O)M100	

Valve connections for copper tubing

Article	Description	Connection	Valve
1885136	Nut and olive	1/2", K12	CTV10, ZTV15, ZTR15, VTTV15, VTTR15, VTTB
1886274	Nut and olive	3/4", K15	CTV15, ZTV20 (kvs 2.0-2.5), ZTR (kvs 2.0-2.5), VTTV20 (kvs 2.5), VTTR20 (kvs 2.5), VTTB20 (kvs 2.5)
1884709	Nut and olive	3/4", K18	CTV15, ZTV20, ZTR20, VTTV20, VTTR20, VTTB20
1886282	Nut and olive	1", K22	CTV20, ZTV25, ZTR25



Suitable valve actuators

Valve actuator	Supply voltage	Control signal
RTAM100-24	24 V AC/DC	On/off, NC
RTAOM100-24	24 V AC/DC	On/off, NO
RTAM100-24A	24 V AC	0...10 V DC, NC
RTAOM100-24A	24 V AC	0...10 V DC, NO
RTAM100-230	230 V AC	On/off, NC
RTAOM100-230	230 V AC	On/off, NO

Dimensions

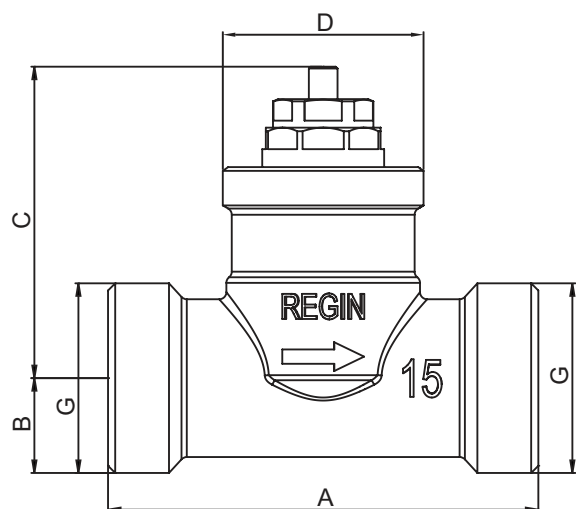

Model	A	B	C	D	G
CTV10	54	1,5	45	M28 x 1,5	G 1/2"
CTV15-1,9	60	13	45	M28 x 1,5	G 3/4"
CTV20	68	16,5	45	M28 x 1,5	G 1"

Measurements in mm unless otherwise specified.

Adjustable kvs value

The kvs value is set by turning the grey plastic cap until the desired number on the cap is aligned with the reference marking in the valve (see the picture below). Depending on the position number selected on the plastic cap, different kvs values are set according to the table below.



Model	Position 1	Position 2	Position 3	Position 4	Position 5	Position 6	Position 7	Position 8
CTV10	0.12	0.22	0.34	0.55	0.7	0.9	1.07	1.14
CTV15-1,9	0.17	0.35	0.50	0.75	1.0	1.25	1.65	1.9
CTV20	0.15	0.35	0.55	0.74	0.9	1.1	1.36	1.55

Pressure drop diagram

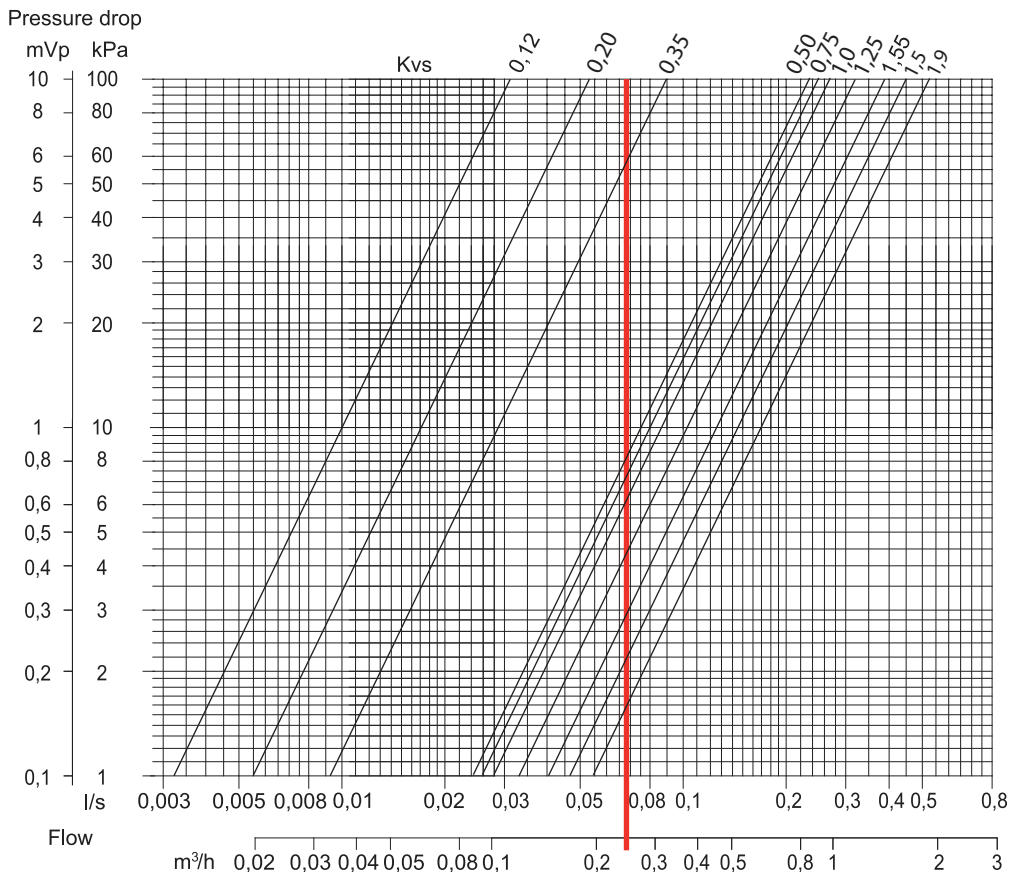

The valves have adjustable kvs value (kvs = the flow in m³/h at a pressure drop of 100 kPa).

To draw a curve for other settings than the pre-drawn values:

Draw a vertical line through the flow. The starting point of the angled line is where the vertical line intersects the top of the chart (at 100 kPa). The angled line should be parallel to the pre-drawn lines.

In the example above, the kvs value = 0.25.