



# RDAB10-24A

Damper actuator, 10 Nm

Damper actuator for control of dampers in ventilation systems.

- Torque 10 Nm
- For dampers up to approximately 2 m<sup>2</sup>
- Power supply 24 V AC/DC
- (0)2...10 V DC continuous control signal

RDAB10-24A is a damper actuator for control of dampers in ventilation systems. The actuator is controlled by means of a standard control signal (0)2...10 V DC. It opens to the position dictated by this signal. The measuring voltage U allows the damper position (0...100%) to be electrically indicated and serves as a follow-up control signal for other actuators.

### Simple direct mounting

The damper actuator is easily mounted on the damper spindle with the universal spindle clamp. The actuator is supplied with an anti-rotation strap that prevents it from rotating.

### Function

Manual operation is possible with the self-resetting pushbutton (the gearing latch remains disengaged as long as the pushbutton is pressed).

The angle of rotation is adjustable with mechanical end stops.

### High functional reliability

The actuator is overload-proof, requires no limit switches and stops automatically when the end stop is reached.

## Technical data

Supply voltage	24 V AC 50/60 Hz, 24 V DC
Power consumption	
In operation (at nominal torque)	2 W
At rest	0.4 W
For wire sizing	4 VA
Sound power level	Max. 35 dB (A)
Control signal input Y	(0)2...10 V DC, input resistance 100 kOhm
Working range	2...10 V DC
Measuring voltage	2...10 V DC, max. 1 mA
Synchronisation tolerance	+/- 5%
Direction of rotation	Selectable with switch
Torque	Min. 10 Nm at nominal voltage
Angle of rotation	Max. 95°, adjustable 0...100% with mechanical end stops
Running time actuator	150 s
Position indication	Mechanical
Protection class	IP54
Ambient temperature	-30...+50°C
Storage temperature	-40...+80°C
Weight	Appr. 800 g
	The product conforms with the requirements of European EMC standard 89/336/EEC and carries the CE-mark.



## Wiring

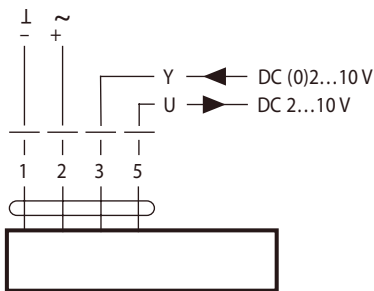

## Dimensions

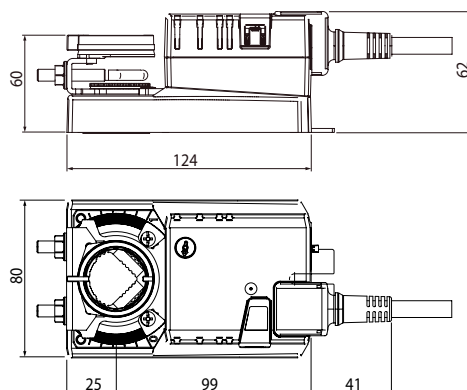

Damper spindle	Length	⊙ I ⊠
Clamp on top	min. 40	8 ... 26.7
Clamp on bottom	min. 20	8 ... 20

Measurements in mm