



RDAB5S-230...

Damper actuator with spring return, 4 Nm

Damper actuator for control of dampers in ventilation systems.

- Torque 4 Nm
- For dampers up to approximately 1 m²
- On/off control

The spring return motors RDAB5S-230 and RDAB5S-230S are used to control small dampers to open or closed position in the event of power failure.

Spring return

When connecting the supply voltage the actuator moves to the working position, at the same time the spring return tenses. If the power supply is interrupted, the energy stored in the spring moves the damper back to its safe position.

- Spring return in the event of power failure
- Selectable direction of rotation
- Mechanical angle of rotation limiting

Simple installation

The damper actuator is fitted with a universal spindle clamp for quick and easy mounting directly on the damper spindle. The actuator is supplied with an antirotation strap for fixing it in position. The angle of rotation is adjustable with mechanical end stops.

The damper actuator is supplied with 1 m cable.

High functional reliability

The actuator is overload-proof, requires no limit switches and stops automatically when the end stop is reached.

Flexible signalisation

RDAB5S-230S has a built-in adjustable 0...100% auxiliary switch.

Models

RDAB5S-230	Basic model
RDAB5S-230S	Model with built-in auxiliary switch

Technical data

Supply voltage	230 V AC 50/60 Hz
Power consumption	
Motoring	5 W
Holding	3 W
Direction of rotation	Selectable by left or right mounting L/R
Torque	Min. 4 Nm, at nominal voltage (also 4 Nm at spring return)
Angle of rotation	Max. 95°, adjustable 37...100% with mechanical end stops
Running time	
Actuator	40...75 s (0...4 Nm)
Spring return	Appr. 20 s at -20...50°C / max. 60 s at -30°C
Sound power level	
Actuator	Max. 50 dB (A)
Spring	Appr. 62 dB (A)
Service life	Min. 60 000 operations
Position indication	Mechanical
Protection class	IP54
Ambient temperature	-30°...+50°C
Storage temperature	-40°...+80°C
Auxiliary switch	1 x SPDT 6 (1.5) A, 250 V AC. Switching point: adjustable 0...100%.
Weight	1550 g
CE	The product conforms with the requirements of European EMC and LVD standard 89/336/EEC and 92/31/EEC and carries the CE-mark.

Wiring and Dimensions

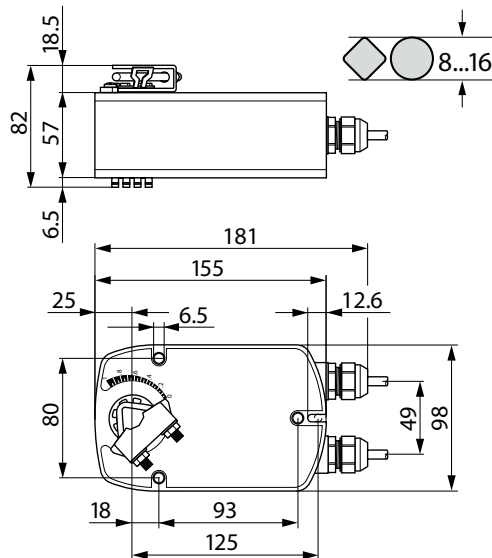
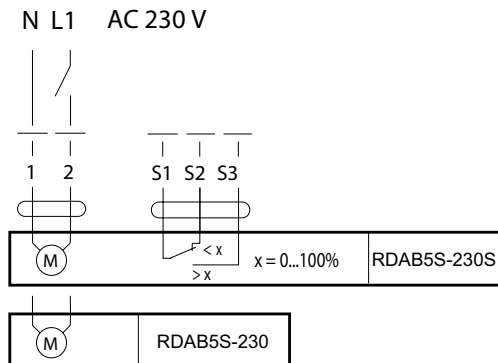

Head Office Sweden

Phone: +46 31 720 02 00
 Web: www.regin.se
 Mail: info@regin.se

Sales Offices

France: +33 1 41 71 00 34
 Germany: +49 30 77 99 40
 Spain: +34 91 473 27 65
 Hong Kong: +852 24 07 02 81
 Singapore: +65 67 47 82 33

REGIN

THE CHALLENGER IN BUILDING AUTOMATION